

Product availability : Stock - Normally stocked in distribution facility

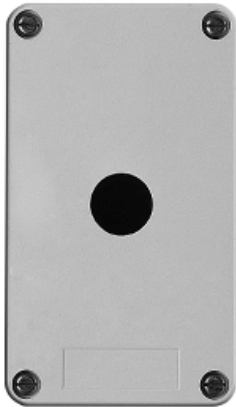

Main

Range of product	Harmony XAP
Product or component type	Empty control station without hinges
Device short name	XAPA
Product destination	For Ø 22 mm control and signalling units
Product front plate size	85 x 146 mm
Usable depth	3.27 in (83 mm)
Number of cut-out	1 cut-out
Colour of base of enclosure	Grey
Colour of cover	Grey
Material	Glass reinforced polyester
Cable entry	Undrilled
Device mounting	Flush
IP degree of protection	IP65 IEC 60529 IP69 NF C 20-010 IP69K
Resistance to chemical agents	High resistant to acids High resistant to all solvents High resistant to bases High resistant to diesel High resistant to mineral salts High resistant to oils and greases High resistant to petrol High resistant to sea water

Complementary

Number of vertical rows	1
Flame retardance	M3 CSTB VO UL 94
Net Weight	0.99 lb(US) (0.45 kg)

* Price is "List Price" and may be subject to a trade discount – check with your local distributor or retailer for actual price.

Environment

Protective treatment	TH TC
Ambient air temperature for storage	-40...158 °F (-40...70 °C)
Ambient air temperature for operation	-40...158 °F (-40...70 °C)
Oversvoltage category	Class II IEC 60536 Class II conforming to NF C 20-030
Fire resistance	1562 °F (850 °C) NF C 20-455 1760 °F (960 °C) IEC 92

Ordering and shipping details

Category	22475 - WALL STATIONS
Discount Schedule	CS2
GTIN	00785901313137
Nbr. of units in pkg.	1
Package weight(Lbs)	1.11 lb(US) (0.50 kg)
Returnability	Yes
Country of origin	FR

Packing Units

Unit Type of Package 1	PCE
Package 1 Height	3.54 in (9 cm)
Package 1 width	5.31 in (13.5 cm)
Package 1 Length	6.10 in (15.5 cm)
Package 2 Weight	14.39 lb(US) (6.528 kg)
Package 3 Weight	139.43 lb(US) (63.244 kg)

Offer Sustainability

Sustainable offer status	Green Premium product
California proposition 65	WARNING: This product can expose you to chemicals including: Di-isodecyl phthalate (DIDP), which is known to the State of California to cause birth defects or other reproductive harm. For more information go to www.P65Warnings.ca.gov
REACH Regulation	REACH Declaration
REACH free of SVHC	Yes
EU RoHS Directive	Pro-active compliance (Product out of EU RoHS legal scope) EU RoHS Declaration
Toxic heavy metal free	Yes
Mercury free	Yes
RoHS exemption information	Yes
China RoHS Regulation	China RoHS declaration
Environmental Disclosure	Product Environmental Profile
Circularity Profile	End of Life Information

Contractual warranty

Warranty	18 months
----------	-----------

Dimensions and Fixing

Refer to the product characteristics to get the number of cut-outs.

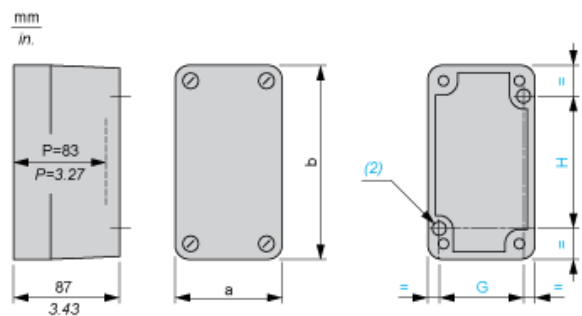

- (2) 2 x Ø 5.6 mm/0.22 in. holes, depth 12 mm/0.47 in.
- P Usable depth

a		b		G		H	
mm	in.	mm	in.	mm	in.	mm	in.
85	3.35	146	5.75	70	2.76	105	4.13